



36% Edge540 ARF Instruction Manual



Congratulations and thank you for purchasing the Performance Aircraft Unlimited 36% Edge 540. The Zivko Edge 540 was designed and developed to be the best aerobatic aircraft in the world and it delivered! Not only does this aircraft dominate IAC competition but has also found a home in the Red Bull racing circuit where it has won title after title. The 540 stands for the powerful Lycoming 540 motor, which puts out more than 300hp. Made from modern composites, this aircraft is sure to be on the podium for some time to come.

The PAU Edge is no different! Designed with 2123 sq inches of wing area while keeping the total weight down has made this aircraft a true performer. All wood construction and top quality hardware make it hard to beat. If you want an aircraft precise enough to compete in IMAC or to turn it loose for the wildest 3D maneuvers on the planet, the 36% PAU Edge 540 is the only choice. The Edge 540 return to RC starts today!

We believe you will find this to be one of the finest flying aircraft on the market. Most modelers will find assembly of this aircraft simple and straightforward. We recommend the builder follow the step-by-step instructions to achieve the best performance and to ensure nothing was over looked. This manual also includes tip sections throughout that may help you in key areas during assembly. Please familiarize yourself with this manual before assembly.

This manual is broken down into ten chapters for simplicity:

Chapter 1 - Parts Inventory

Chapter 2 - Preparation for Assembly

Chapter 3 - Landing Gear and Tail Wheel Assemblies

Chapter 4 - Canopy and Fuselage Hatch

Chapter 5 - Engine Installation

Chapter 6 - Cowling installation

Chapter 7 - Rudder Installation

Chapter 8 - Hardware Installation

Chapter 9 - Radio and Control Surface Setup

Chapter 10 - Final Inspection and Pre-Flight

Additional items needed to complete this aircraft, which are not included:

- An engine, within the recommend range, and propeller
- 8 channel computer radio and receiver recommended
- Batteries and switches (with regulators if using Ion batteries)
- Four aileron servos rated at least at 150oz of torque
- Two elevator servos rated at least at 200oz of torque each!
- One or two rudder servo rated at least at 400oz of torque
- One throttle servo with push rod and links
- Optional choke servo with push rod and links
- One fueling dot or fueling device
- 3 to 4 feet of fuel tubing
- Foam rubber
- 4-½ inch spinner
- 30 to 45 minute epoxy
- A bottle of thin CA
- Covering iron
- Various modeling tools for assembly
- ½ inch low tack masking tape

Chapter 1

Parts inventory

Place an “x” to ensure your kit is complete:

- 1 Fuselage
- 1 Fuselage access hatch
- 2 Wing panels (1 right and 1 left)
- 2 Horizontal stabilizers (1 right and 1 left)
- 1 Rudder
- 1 Fiberglass Cowl
- 1 Pair of fiberglass wheel pants
- 1 Aluminum landing gear
- 1 Pair of Dubro Light wheels
- 1 Tail wheel and tiller assembly
- 1 Canopy
- 1 Carbon fiber wing
- 1 Carbon fiber stabilizer tube
- 4 Nylon wing retention bolts
- 6 H9 titanium pushrods/turnbuckles
- 1 set of Dubro wheel collars
- 1 pair of Dubro wheel axels
- 1 HD Dubro pull-pull system
- 1 Set of aluminum control horn assemblies
- 1 32oz Dubro fuel tank
- 8 HD 4/40 Dubro ball links
- 1 Set of additional various marked hardware
- 1 Vinyl graphics package



If any of these parts are missing immediately contact PAU.

If you need more information you can visit our support forum at: flyinggiants.com

Chapter 2

Preparation for Assembly

Professionals utilizing premium Ultracote covering carefully covered your model. Due to climate changes during shipping, the models covering may have loosened and/or wrinkled. It's a good habit to go over your model with a covering iron to ensure all joints, seams, and edges are properly sealed.

Ultracote is a lower temperature film that seals and shrinks at lower temperatures. Make sure you set your iron on a low temperature initially to get a feel for the correct temperature setting and adjust accordingly. Higher temperatures will cause your covering to over shrink and distort. Also, use a sock over your iron to ensure a scratch free finish.

Place an "x" to ensure task completion:

- Go over you model as necessary with a covering iron to insure all joints, seams, and corners are sealed properly.

- Use your iron to ensure the areas where cutouts are needed for your hardware are located and sealed down, such as servos; tubes, and control horn mounting locations.



Next, we'll need to cut out the covering at the locations for hardware and final assembly. Make sure you use a sharp hobby knife so your cuts will be clean and straight.

- Start with the fuselage, Locate and cut out the servo and stabilizer and wing tube locations.

- Locate and cut the location for the anti-rotation pins and mounting holes for the stabilizers and wings.

- Locate and cut the two mounting bolt locations for the canopy and the two pull-pull exits.

- Locate and cut the servo mounting locations for each wing half.



Chapter 3

Landing Gear and Tail Wheel Assemblies

Now that we're ready for assembly, we are going to start with the main landing gear first. You will need to locate the following parts to begin assembly.

Place an "x" to ensure task completion:

❑ What you will need in this chapter for the main gear:

- ✓ Aluminum main gear
- ✓ One pair of 4 inch wheels
- ✓ One pair of wheel pants
- ✓ One pair of Dubro axles
- ✓ Four wheel collars
- ✓ Hardware pack marked "wheels"
- ✓ Fuselage
- ✓ Rudder
- ✓ Tail wheel assembly

Not Provided:

- ✓ 1/2" and a 9/16" inch wrench
- ✓ Blue loc-tite
- ✓ Allen wrench for wheel collars
- ✓ White wood glue such as Elmer's or Epoxy



- ❑ Fasten the axles to the main landing gear with the lock nuts.
- ❑ Using your four wheel collars and wheels, center you wheels on the axles. Place the collars as close to the wheels as possible but ensure the wheels still rotate freely. Again, we don't want the wheel to move from side to side and contact the wheel pants. Also, we recommend the use of loc-tite on the setscrews of the wheel collars to prevent them from vibrating loose.



- ❑ First you'll need to knock out the plywood opening the canister tunnel. Use a hobby knife on the small area not cut with a laser and lightly tap it out with a small hammer.
- ❑ Install the landing gear to the fuselage using the four 8/32 bolts, spring washers, and flat washers, and compression nuts.



Now let's get the tail wheel assembly installed.

- ❑ Once the mains are on, find the pre-drilled hole for the tail wheel assembly. Insert the tail wheel assembly and lightly tap in flush with a small hammer.
- ❑ Next, mark the hold down locations, drill and mount them with the four wood screws securing the tail wheel assembly. Remove the wood screws and coat the holes with thin CA, let dry, reinstall.
- ❑ Install the steel tiller horn just behind the hinge line on the bottom of the rudder using the two small wood screws.



Tip#2 Set aside your two tiller springs, we will install those later after the rudder is mounted.

- ❑ Cut out the center wheel opening on the wheel pants on the side with the wood-mounting block.
- ❑ With the aircraft resting on the landing gear, we are going to need to set the right angle for the wheel pants. We used a standard servo and placed it at the end of the pant resting the end on the rubber grommets of the servo. Mark the drilling location for the 4/40 bolts.
- ❑ Drill the holes for the 4/40 bolts in the wheel pants at the locations you've marked.



- ❑ Apply some white wood or epoxy glue to the inner side of the four 4/40 blind nuts and install the blind nuts to the inside of the wheel pants.
- ❑ Now you can install the wheel pants with the 4/40 bolts and washers. Don't forget to use loc-tite here again. Wheel pants tend to take the most vibration.



Chapter 4

Canopy and Fuselage Hatch

Place an “x” to ensure task completion:

- ❑ Gather the following for canopy and hatch installation:
 - ✓ Canopy
 - ✓ Fuselage and Access Hatch
 - ✓ 8 small wood screws
 - ✓ Two 4/40 bolts with two sealing washers

Not Provided:

- ✓ Drill and small drill bit for wood screws
- ✓ Canopy glue (optional)
- ✓ Thin CA
- ✓ Ruler

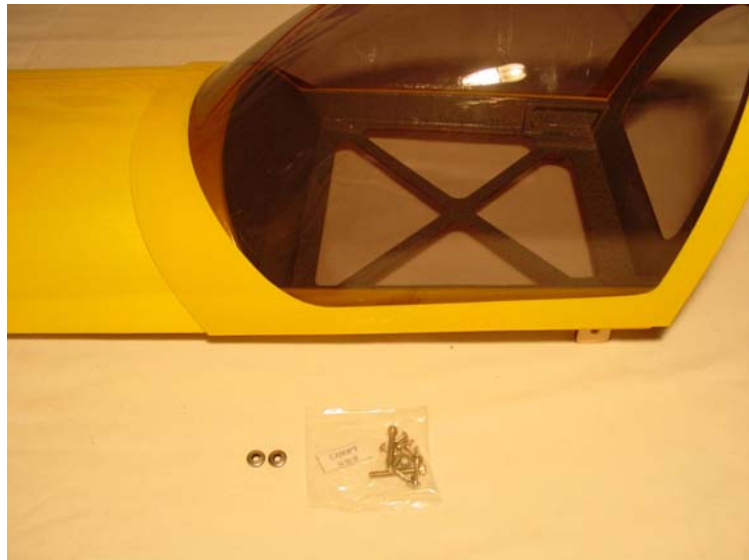

- ❑ Install the hatch on the fuselage using two 4/40 bolts with the self-sealing washers.
- ❑ Trial fit the canopy to the fuselage access hatch to determine screw locations.
- ❑ Mark four evenly spaced locations for the screws on each side. Double check to ensure all the marked screw locations will go into the hatch rail.
- ❑ Remove canopy from the access hatch and drill the marked locations for the canopy screws.



- ❑ Install the canopy using the small wood screws. If satisfied with the fit, remove the canopy and hatch and wick a small amount of thin CA into each of the screws holes on the hatch. Once dried, reinstall canopy with optional canopy glue if desired. **Caution!** CA will fog the canopy if installed before completely drying.



Chapter 5

Engine Installation

Your firewall is pre-mounted but our customers can select from a wide variety of engine choices. It is nearly impossible to cover every engine installation choice in this manual but we'll cover a few. Your aircraft was designed around the 100cc twin gas motors. Also, we have provided a canister tunnel on our Edge for those who desire quieter operation. Please consult the manufacturer for the installation of optional canister.

Your Edge540 will also accept lighter motors like the DA-85. If using the DA-85, attention should be paid to your hardware installation as it may need to be mounted towards the front of the aircraft for proper CG.

We will cover the installation of two popular engine choices in this manual, the DA-85 and the DA-100 motors. Follow your engine manufactures instructions for any additional guidance. Let's get started!

Place an "x" to ensure task completion:

What you will need in this chapter:

A DA-100 mounting template found in the back of this manual or a DA-85 mounting template found in the back of the DA-85 manual.

Not Provided:

- ✓ **1-1/4" standoffs for the DA-100**
- ✓ *1-7/8" mount for the DA-85*
- ✓ **Four 1/4-20 bolts 2-1/2" long for the DA-100**
- ✓ *Four 1/4-20 bolts 3-1/4" long for the DA-85*
- ✓ Four lock or compression nut with fender washers
- ✓ An engine in the recommend size range
- ✓ 4 1/2 inch spinner
- ✓ Propeller
- ✓ A drill and drill bits
- ✓ Center punch
- ✓ Scotch tape for template



Also with the engine is installed, you will want 7-3/4 inches from the firewall to the spinner back plate for proper cowl placement.

DA-100 installation

- ❑ The firewall is pre-marked so you'll just need to center your motor in the "+". Take a ruler and draw a line across the entire firewall for the thrust line and offset centerline.
- ❑ **DA-100 users only.** If using the DA template provided on the last page of this manual, check the measurements on the template and ensure the holes are correct. Cut the paper template to the size needed to tape it to the firewall using your thrust line and offset centerline as a guide. Mark the drilling locations and drill holes for 1/4-20 bolts.

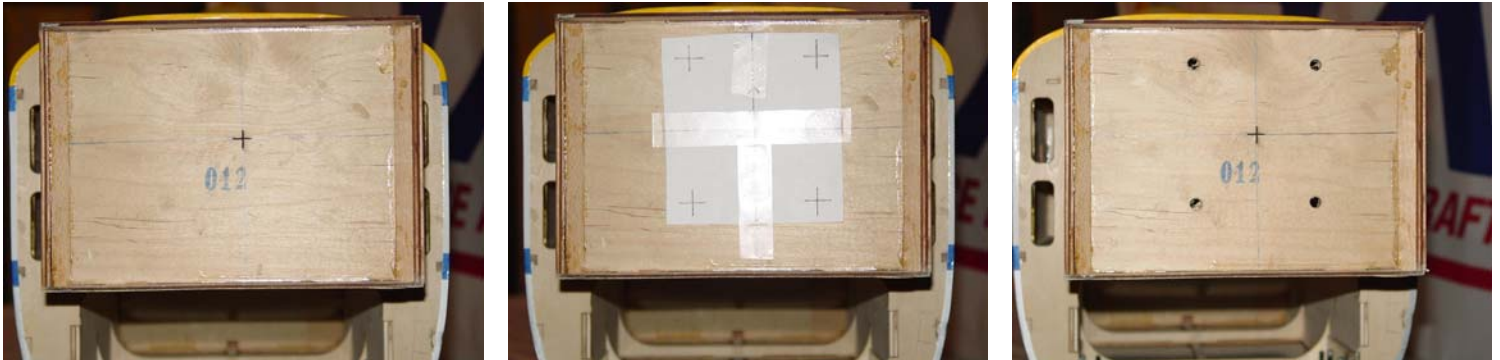

- ❑ Mount the motor using 1-1/4" standoffs for the DA-100, and four 1/4-20 x 2-1/2" long bolts.
- ❑ Now that you have the motor mounted, mark the locations for the fuel line and throttle push rod remove motor and drill those locations and reinstall motor.



We recommend 4/40 push rods for throttle and/or optional choke servo. Also ensure there is no metal-to-metal contact from the throttle/choke to the servos. 2/56 Ball links for 4/40 rod (not included) will prevent the aforementioned metal-to-metal contact and will bolt to nicely to your motors carburetor.

DA-85 installation

- ❑ You will just need to center your motor in the "+". Take a ruler and draw a line across the entire firewall for the thrust line and offset centerline.
- ❑ **DA-85 users only.** If using the DA template provided on the last page of your **DA manual**, check the measurements on the template and ensure the holes are correct. Cut the paper template to the size needed to tape it to the firewall using your thrust line and offset centerline as a guide. Mark the drilling locations and drill holes for 1/4-20 bolts.

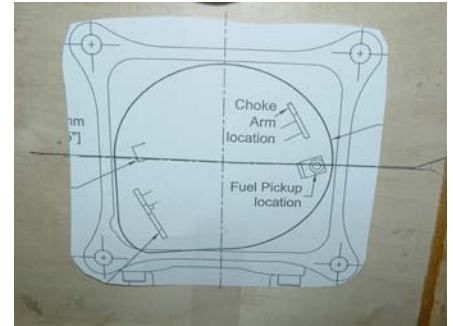

- ❑ Desert aircraft recommends not using standoffs with the DA-85. You will need to make a mount to properly install this motor. We used the template provided by DA and made several light plywood rings stacked to achieve the correct standoff, which is approximately 1-7/8" off the firewall.
- ❑ Mount the motor using 1-7/8" solid mount for the 85, and four 1/4-20 x 3-1/4" long bolts.
- ❑ Now that the motor is mounted, mark the locations for the fuel line and throttle push rod remove motor and drill those locations and reinstall motor. Another recommended option is to use the template and cut a hole in the firewall for the carburetor, which will make installing push rods and fuel lines easier.

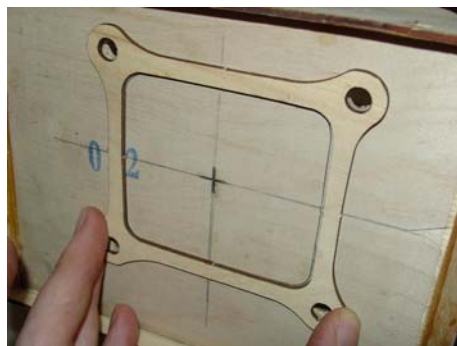

We recommend 4/40 push rods for throttle and/or optional choke servo. Also ensure there is no metal-to-metal contact from the throttle/choke to the servos. 2/56 Ball links for 4/40 rod (not included) will prevent the aforementioned metal-to-metal contact and will bolt to nicely to your motors carburetor.

Chapter 6

Cowling installation

Place an “x” to ensure task completion:

- ❑ What you will need in this chapter:
 - ✓ Fuselage and cowling
 - ✓ Five 6/32 bolts with spring and lock washers

Not Provided:

- ✓ A 4-½ inch spinner
- ✓ A Dremel tool
- ✓ A facemask and eye protection
- ✓ Pencil or dry erase marker



Always wear a mask and eye protection while cutting fiberglass. Take your time while installing the cowl. With care you will end up with a professional installation that will make an impression at the field.

Close the choke and place a piece of tape over the carburetor inlet and exhaust outlet to keep out any dust while setting up your cowl. Since the cowl is preset and uses a ring to mount, there will not be much to do here.

- ❑ First cut out the bottom opening for cooling. **For the DA-100 using canisters**, you will only need to open the bottom of the cowl to exit the air from the cowl. If you're using stock exhaust stacks, it may be necessary to cut away the bottom portion of the cowl ring for it to pass the exhaust.
- ❑ If using stock mufflers for the DA-100, we recommend the compact style.
- ❑ **For the DA-85**, measure and cut an opening for the cylinder head and muffler just enough to get the cowl mounted.
- ❑ Now we are ready to do some fine trimming for the DA-85. We will want to cut at least an extra 1/4 inch cut around any of the engine components that protrude. Mark any additional areas that may require trimming.
- ❑ Remove the cowling and cut out the remaining areas to be trimmed.

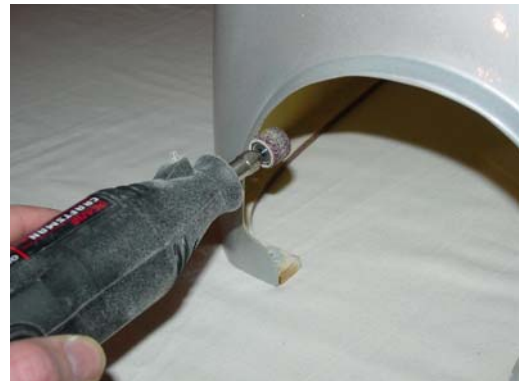

Chapter 7

Rudder Installation

Place an “x” to ensure task completion:

- ❑ What you will need in this chapter:
 - ✓ Rudder and fuse
 - ✓ Pull-pull hardware

Not Provided:

- ✓ 30 to 45 minute epoxy
 - ✓ Two cycle oil
- ❑ Next, we will install the hardware on the rudder before mounting the rudder. Find the pre-drilled hard point, remove the covering and insert the longer 4-1/2” stainless threaded rod provided.
 - ❑ Install the Dubro fasteners to the rod. Use loc-tite as shown if you are not planning on using the lock nuts.
 - ❑ Now add the control horns placing them at 2” from the hinge line.
 - ❑ Now were going to prep the hinges for installation. Take a small drop of oil and place it in each of the pivot points of your hinges. The oil prevents excess epoxy from bonding the joint.
 - ❑ Apply epoxy into the trailing edge holes of the vertical stabilizer. Now apply epoxy to the hinges.
 - ❑ Carefully insert the control surface into the stabilizer and butt the two surfaces together. Move the surface back and forth a couple of times to make sure all the hinges are aligned correctly and the desired throw is attained. You will want at least 45 degrees.
 - ❑ Use some masking tape to hold the surfaces together and let cure for at least eight hours.
 - ❑ Install the tiller springs you set aside in chapter 2 to the tiller horn and tiller.

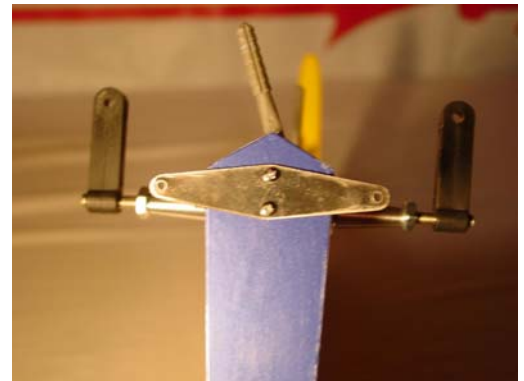

Tip#5 Optional step. After your epoxy has cured, it would be a good time to seal all of your hinge gaps prior to installing the rest of the hardware. This can provide you with a better flying aircraft by increasing control surface performance and preventing possible flutter. Clear or matching covering material can be ironed in place to fill any gaps on the bottom of your control surfaces.

Take approximately a one-inch strip of covering the length of your surface. Fold it in half while placing into the gap with the control surface fully deflected up and iron it in place. Check to make sure you still have full surface travel once you have completed.

Chapter 8

Hardware Installation

We provide high quality aluminum control horn assemblies included with our latest generation of PAU aircraft kits. We believe these lightweight assemblies are the best available and can also be purchased separately from PAU.

Place an “x” to ensure task completion:

- What you will need in this chapter:
 - ✓ The entire airframe
 - ✓ Six H9 titanium push rods
 - ✓ Six sets of aluminum control horn assemblies
 - ✓ Six steel posts
 - ✓ Eight HD Dubro ball links
 - ✓ One 32oz Du-bro fuel tank

Not Provided:

- ✓ Four 150oz or better servos for ailerons
- ✓ Two 200oz or better servos for elevators
- ✓ One or two servos for rudder equaling 400oz
- ✓ One throttle servo 70oz or better
- ✓ Six 1.5” aluminum servo arms
- ✓ One 4” offset rudder servo arm
- ✓ One Fuel dot or other fueling device
- ✓ Some foam rubber for mounting receiver, ignition module, and fuel tank



Install all your flight control servos with the output shaft closest to the control surface.

- Install 150oz or better servos for the ailerons in the servo trays located in the bottom of the wings.
- Install 200oz or better servos for the elevators in the servo trays located in the bottom of the horizontal stabilizers.
- Install one or two equaling 400oz or better servos for the rudder in the servo tray inside the fuselage.
- Install your throttle and or choke servos in the forward bays provided.
- First you need to find the pre-drilled holes for the steel posts. Install the aluminum control horn assemblies to each surface with the M4 bolt in the down position. Use blue loc-tite on the aluminum base to ensure the bolt does not try to back out under vibration. Screw on the horns on to the posts.
Do not use loc-tite installing the horn.

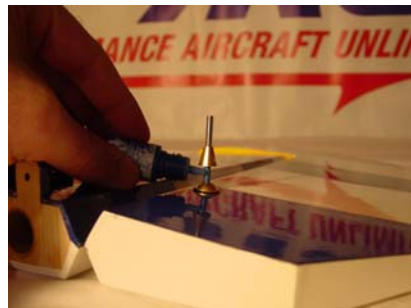
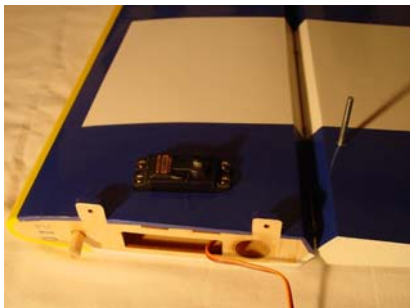

- ❑ Make sure your elevator servos are centered and mount your servo arms parallel to the hinge line.
- ❑ Take some masking tape and tape the elevator counter balances to the stabilizers so that they are in a center position.
- ❑ Screw in your two HD ball links onto the counterclockwise ends of the 2" H9 push rods and screw the other end into the control horn. Ensure everything is still centered. Don't forget to add locknuts to the 4/40 bolts when attaching the ball link to the arm.

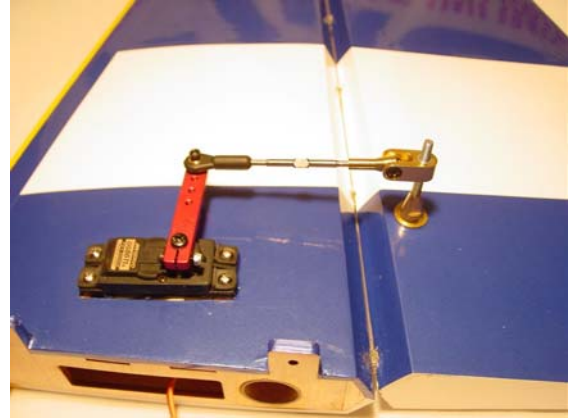

- ❑ Ensure aileron servos are centered and mount your arms parallel to the hinge line.
- ❑ Be sure that you install the horns at the same height from the hinge line (see attached). By doing so you will have very little servo matching to do afterwards.
- ❑ Screw in four HD ball links onto the counterclockwise ends of the 3" H9 push rods and screw the other end into the control horn. Ensure everything is still centered. Don't forget to add locknuts to the 4/40 bolts when attaching the ball links to the arms.



- ❑ Ensure your rudder servo is centered and mount your rudder servo arm.
- ❑ A single JR 8711 servo is used for this manual. If your using two servos, you will need an additional servo arm to tie the two servo together as well as a servo matching devise.



- ❑ Install your pull-pull cable and your remaining pull-pull hardware. Cables should be crossed to avoid any rubbing on the exits. It is normal for the non-pulling side of the cable to slacken a little when the rudder is deflected.
- ❑ Install your tiller springs you set aside earlier.



- ❑ Assemble the fuel tank according to the directions provided on the package. You will need to decide whether you want a two or three-line setup. With a two-line setup you will need an additional “T” fitting in the carburetor line that connects to your fuel dot or fueling device. Make sure you use Tygon fuel tubing inside the tank for the clunk as well.
- ❑ Install the fuel tank just in front of the wing tube using zip-ties or hook and latch (Velcro) straps. Place a loop in the vent line over the top of the tank to prevent fuel loss during flight and improve flight times. Take small zip-ties or fuel line clamps and fasten to all the points where the fuels lines connect.

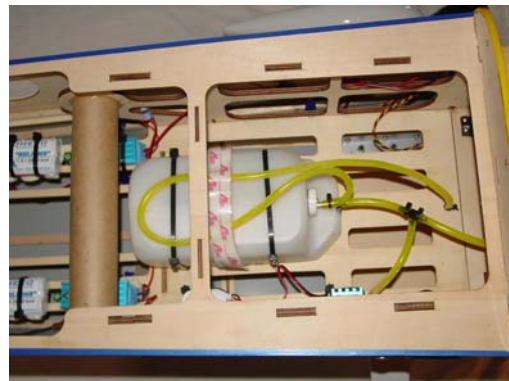

- ❑ There are two switch locations on the forward part on each side of the fuse. They will both accept HD standard switches. Mount your switches at this time.
- ❑ Install the fuel-filling device in a location of your choice. In this case, we installed it just behind the ignition switch.



- ❑ Install your throttle push rod. Again as mentioned earlier, we do not want metal-to-metal contact at the attachment point on the engine. Use a 4/40-rod with a 2/56 ball link for 4/40 rod to attach the push rod to the motor.
- ❑ Once satisfied with your throttle setup, mount the cowl using the five 6/32 bolts provided and attach the prop and spinner.



- ❑ Install the horizontal stabilizers at this time. Install the carbon fiber stabilizer tube. Slide in each half and secure them with the four 4/40 retention bolts.
- ❑ Install the horizontal stabilizers at this time. Install the carbon fiber stabilizer tube. Slide in each half and secure them with the four 4/40 retention bolts.
- ❑ Lets install the wings at this time and check our center of gravity (CG). Install the carbon fiber wing tube. Slide in each wing panel and secure them with the four nylon wing retention bolts.

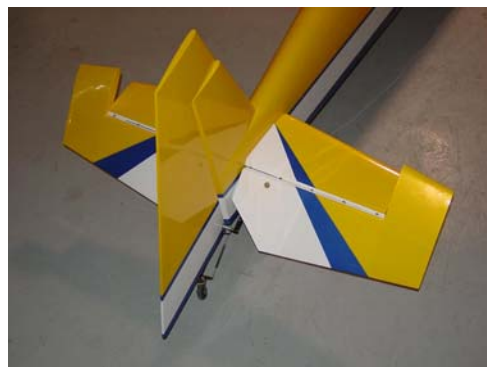

Tip#8 If the wing is tight you can coat the tube with a little baby powder to aid the insertion of the wing panels.

Tip#9: For added protection in case the wing retention bolts back out during flight; you can add hitch pins to the anti-rotation pins of the wing. With the wings installed, mark the anti-rotation pins 1/4 inch from the fuselage side. Remove the wings and drill a small hole in the anti-rotation pins. You can find appropriate sized hitch pins at most local hardware stores. Re-install wings and insert the hitch pins for added protection.

Now we're ready to check the CG and install your remaining hardware. The CG range is 6 to 7 inches back as measured where the wing meets the fuselage. We recommend 6-1/2 inches for initial flights.

- ❑ Check CG at this time and place your batteries and remaining hardware in locations to attain the desired CG. If satisfied mount your remaining hardware.

Congratulations! You have just completed assembly of your Edge540. Now would be a good time to install the optional vinyl graphics included with your kit.

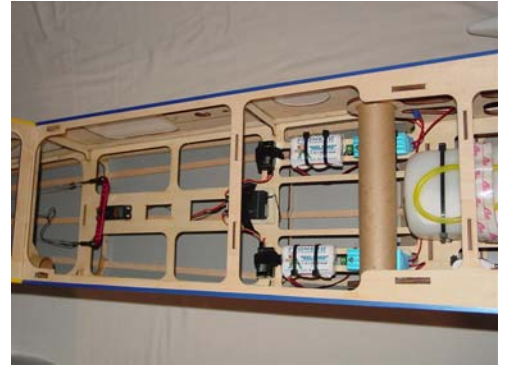

Chapter 9

Radio and Control Surface Setup

Now we are ready to setup your aircraft for flying. Included in this manual are templates for measuring surface throw you may use if desired. We recommend that you setup your aircraft on low rates for initial flights until you become familiar with the aircraft and its capabilities.

The recommended low rates for this aircraft are:

25 degrees for ailerons with 0 to 20% expo
15 degrees for elevators with 0 to 20% expo
30 degrees for rudder with 0 to 20% expo

The recommended high rates for this aircraft are:

35 degrees for ailerons with 40 to 70% expo
45 degrees for elevators with 40 to 70% expo
45 degrees for rudder with 30 to 70% expo
or as much as you can stand for hardcore flyers.

CG Range is 6 to 7 inches.

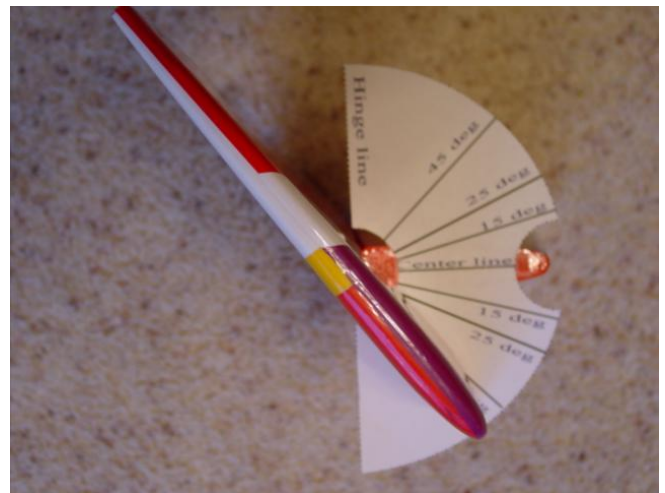

Place an "x" to ensure task completion:

- ❑ What you will need in this chapter:
 - ✓ Completed airframe
 - ✓ Radio
 - ✓ Throw templates or meter
- ❑ Cut out the templates for surface throw. These should be located on the last page of this manual.
- ❑ Tape each one in place using the horizontal line as a reference point to each stabilizer at the counter balance and at the inside of the wings where the ailerons meet.
- ❑ Set your throws accordingly. Double check to make sure nothing is binding to include the throttle and or choke servos and their linkages. Also, ensure all surfaces and controls are moving in the proper directions.

Chapter 10

Final Inspection and Pre-Flight

Welcome to the final chapter prior to your maiden flight. We hope you have enjoyed building your Edge 540.

Lets go over the airframe and perform a pre-flight to make sure everything is in order.

- Inspect the airframe for any visible damage and loose covering that may have occurred during the build.
- Inspect the main landing gear and tail wheel assembly. Ensure all mounting hardware and collars are fastened properly.
- Inspect your motor installation and cowl to ensure all bolts are tight and the muffler is firmly mounted in place. Check the motor and muffler for possible contact with the cowl. Inspect ignition module and spark plug wire for proper mounting. Check propeller and spinner to ensure they are both secure.
- Inspect the inside of the fuselage to ensure your batteries, switches, regulators (if equipped), fuel tank and lines are securely fastened. Check nylon wing bolts to ensure they are in place and secured.
- Inspect all control surfaces and control surface hardware. Gently tug on each surface to make sure the hinges are properly bonded. Check the four 4/40 horizontal stabilizer fasteners and ensure they're in place and secured.
- Check all servos for mounting screws. Check servo arm mounting screws and inspect that the 4/40 links have been secured with lock nuts.
- Fill fuel tank and inspect for any leaks.
- Check your batteries in both your aircraft and radio to ensure they are fully charged
- Turn on radio to inspect all controls for binding, proper direction and throw while on high rates.
- Re-check CG. It should be anywhere from 6 to 7 inches depending on your flying style.
- Secure aircraft using a buddy or hold down and start motor according to manufacturers guidelines. Don't forget to lower your throttle prior to ignition.
- Perform a proper range check with the motor running using your radio manufacturers instructions.
- Make sure you go back to low rates for your maiden takeoff and enjoy!

This concludes your pre-flight checks. After your maiden flight, repeat these steps to perform a post flight to ensure nothing has loosened. It's always a good habit to use a checklist like this one to go over your aircraft prior to the first flight of the day.

Flying!

We believe you will find this aircraft finest aircraft you've ever flown. High-alpha stability gives you solid control and confidence to bring it right down on the deck! For contest flying such as IMAC, a 6-1/2" CG offers great precision and our airframe is a great choice.

Every airplane has structural limits, and the larger the plane is, the more critical it is to understand and respect these limits. This is particularly true for 3D aerobatic planes, since by design, these planes are light weight, are over powered, and have oversized control surfaces.

Pilots need to use proper throttle management, and avoid high speed when executing high stress maneuvers such as Walls, Parachutes and Blenders. As a general rule, the throttle must be at idle position whenever the nose is pointed down (whether at vertical or 45 degrees down line).

Planes must be inspected frequently, looking for any loosening screws, bolts and glue joints. Servos and linkages must be free of play or "slop", as this is a major cause of flutter (and crashes).

Understanding and applying these few safety and maintenance guidelines will help you get many enjoyable and rewarding flights with your Giant Scale Plane.



We hope this aircraft offers you many years of enjoyment. Thank you again for choosing PAU and look for exciting future products.

Additional products from PAU:

43% Edge 540.

30% Extra 300-SP.

30% Edge III.

27% Pitts Challenger.

27% Pitts Bulldog

37% Ultimate.

60-90 sized Cap Maniac.

Mini Yak 54 Electric, HOT ITEM!

Electric Hydroplane.

A complete line of high performance laminated props.

A choice of light weight Fiberglass and Carbon Fiber Spinners.

Aluminum Hardware sets that weigh next to nothing. Time to chuck your old stuff, its now obsolete!

Other great designs are on their way! Stay tuned.

DA-100 Template
If printing from Adobe, turn off page scaling.

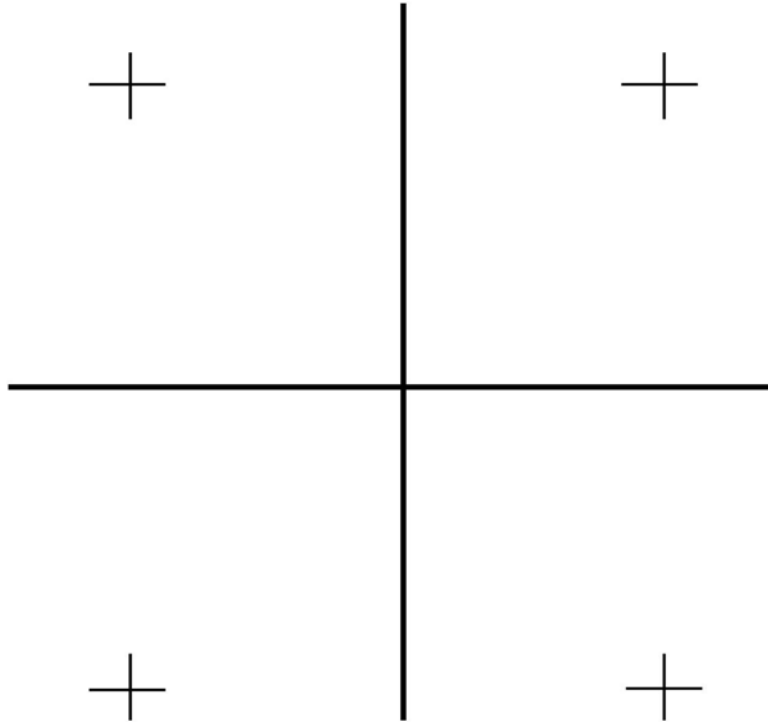

Throw Template

If printing from Adobe, turn off page scaling.

Cut out around all the dotted lines.

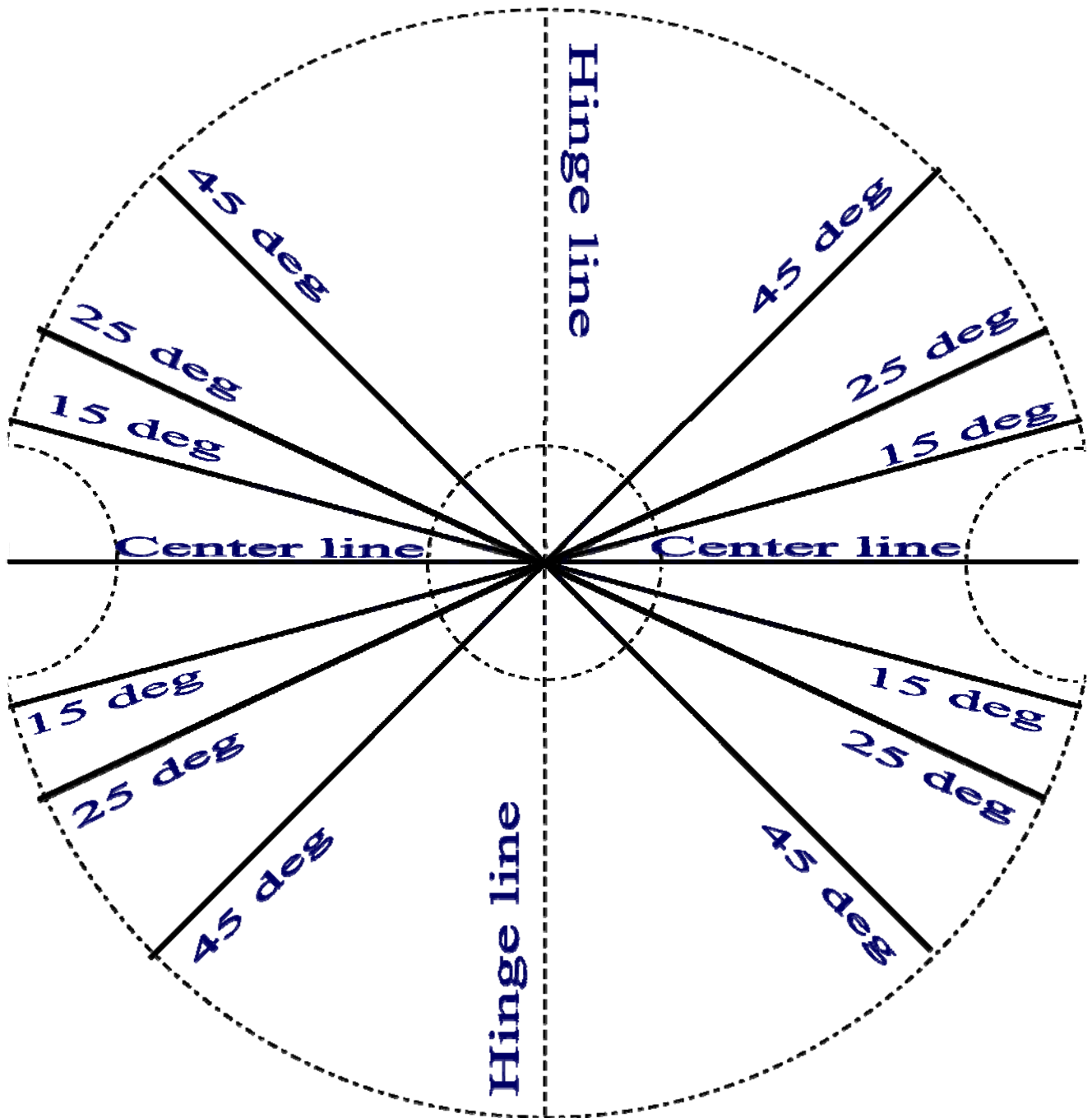

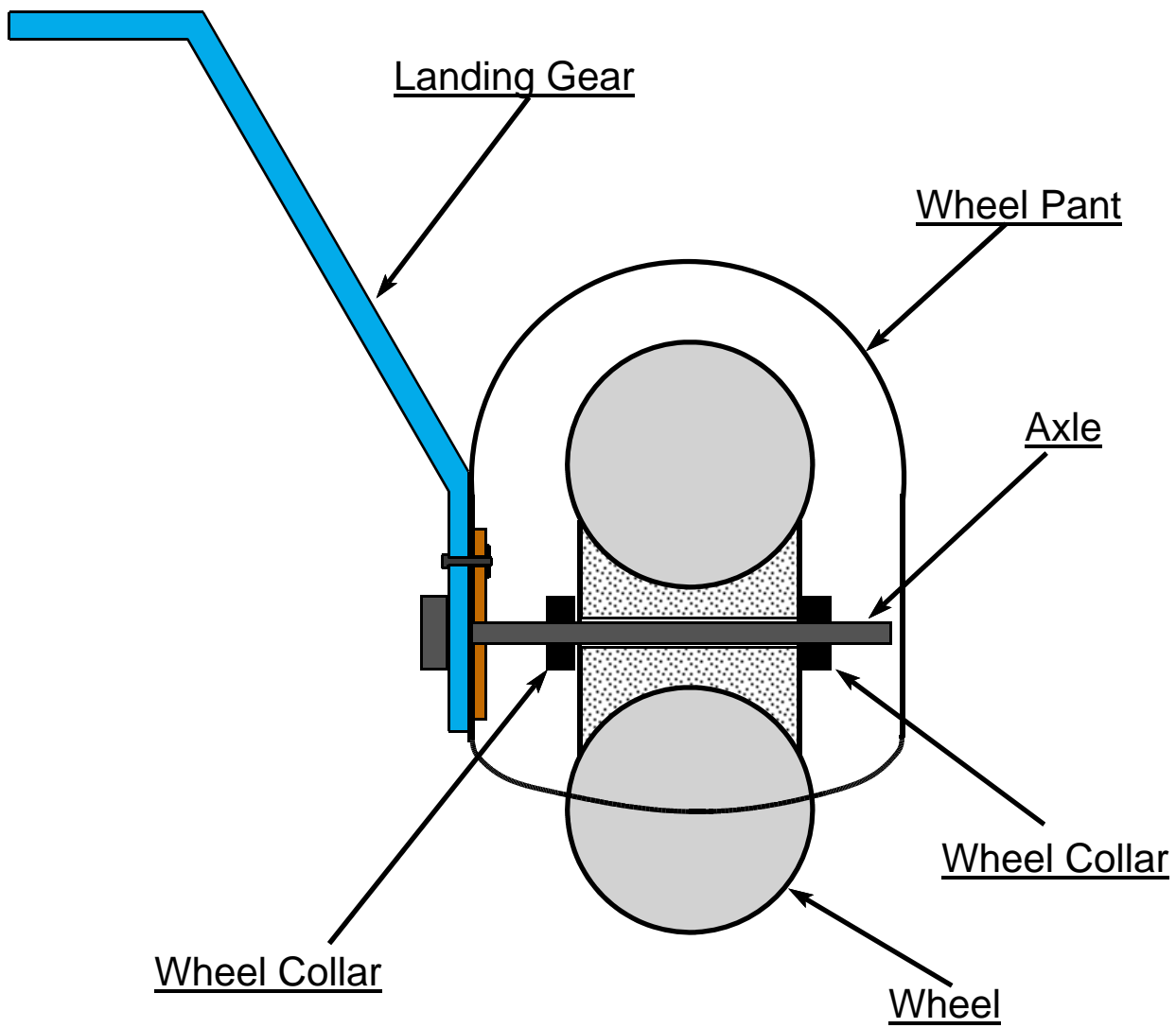

STEP 1: Install wheel pants with typical installation

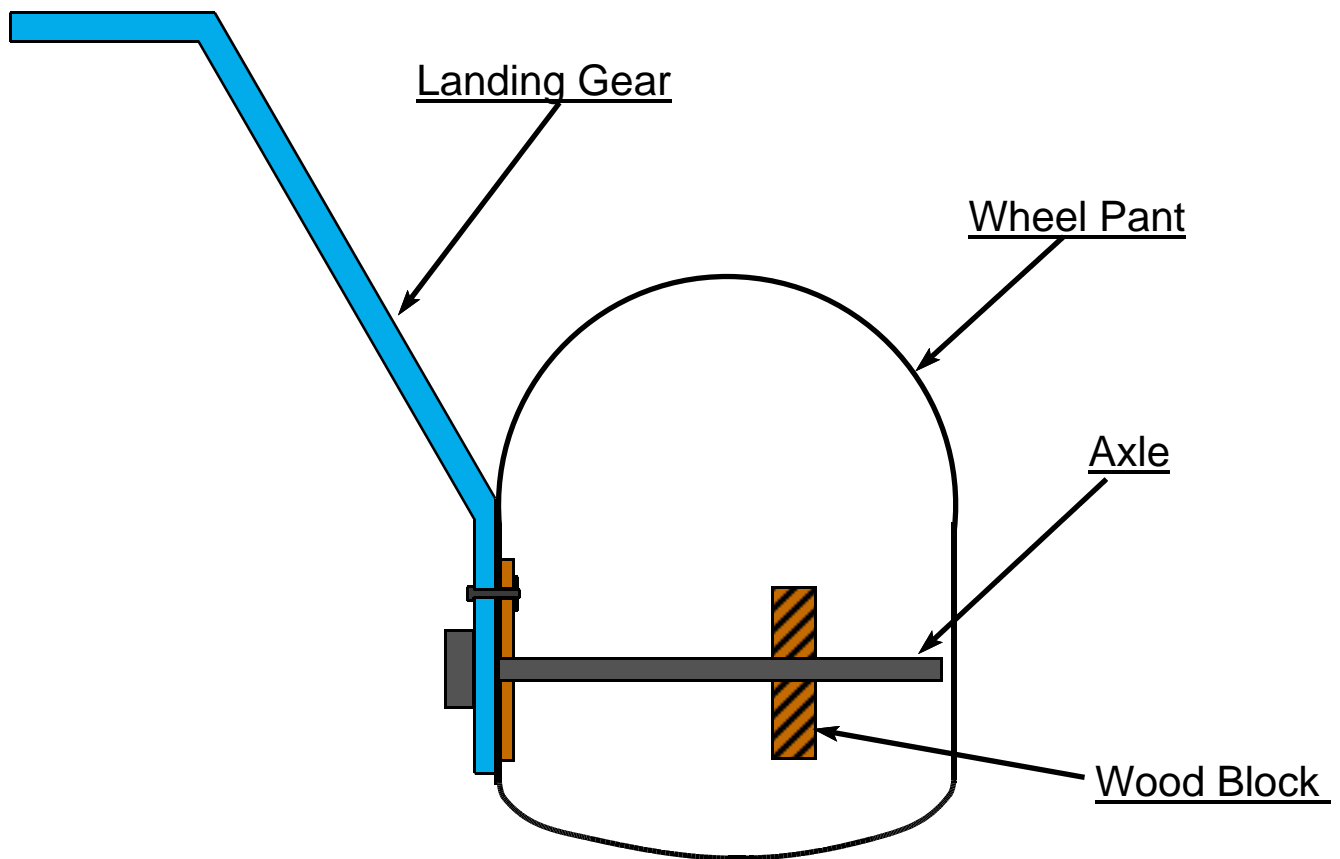

STEP 2: Make a small block of wood (balsa or lite ply) about 1"x1-1/2"x1/4", and drill a hole the size of the axle in the center.

Note: 1/4" Thickness usually works, but needs to be thicker than the gap between the end of the axle and the exterior wall of the wheel pant).

Remove the wheel, and re-install the wheel pants with the small wood block inserted loosely on the axle.

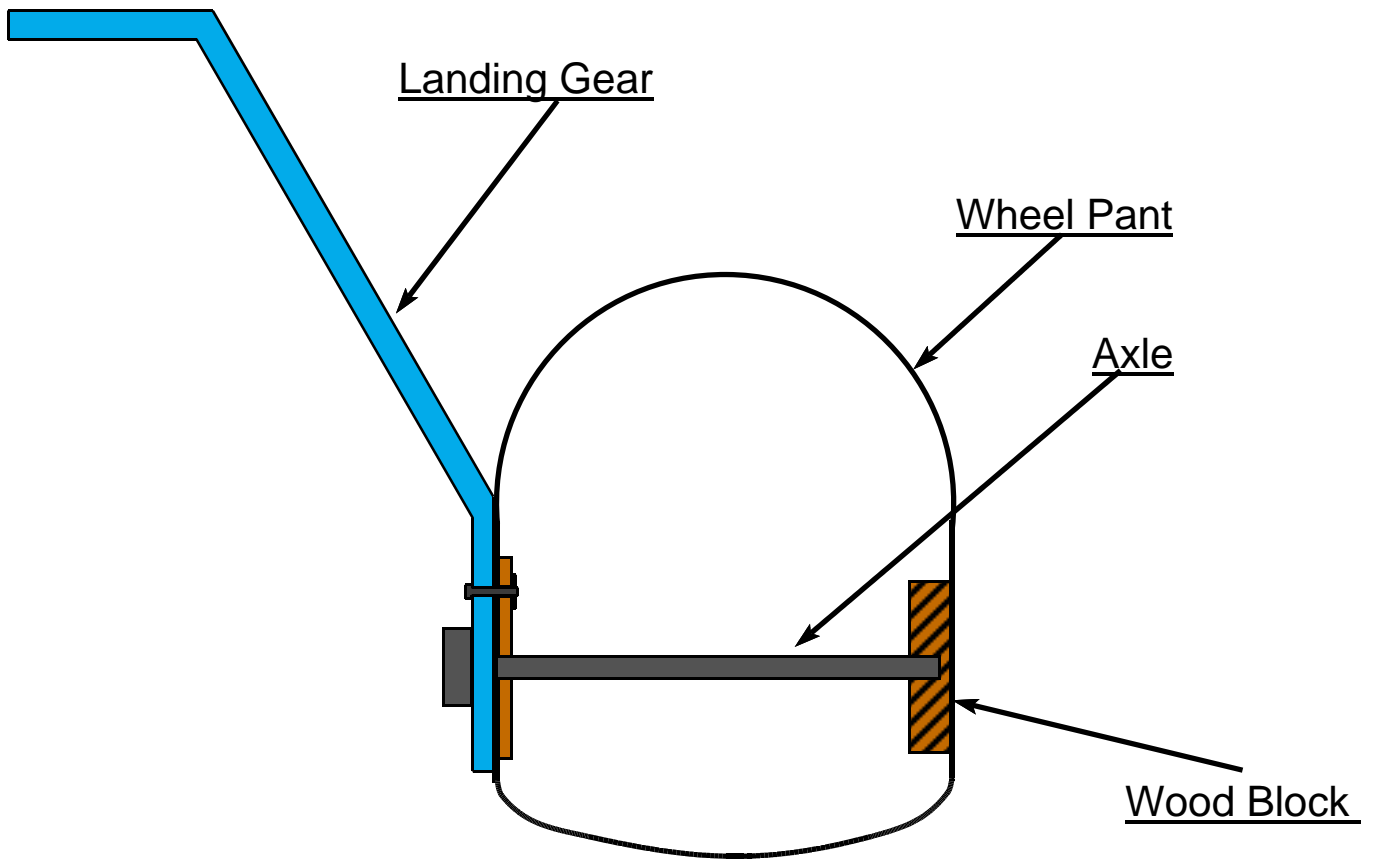

STEP 3: Glue the wood block the wheel pants using epoxy, making sure the wheel pants screws are tight, the wheel pants are seated in their "natural" position, with no stress on the fiberglass. If using a soft wood, it is helpful to harden the wood at the hole for the axle with thin CA.

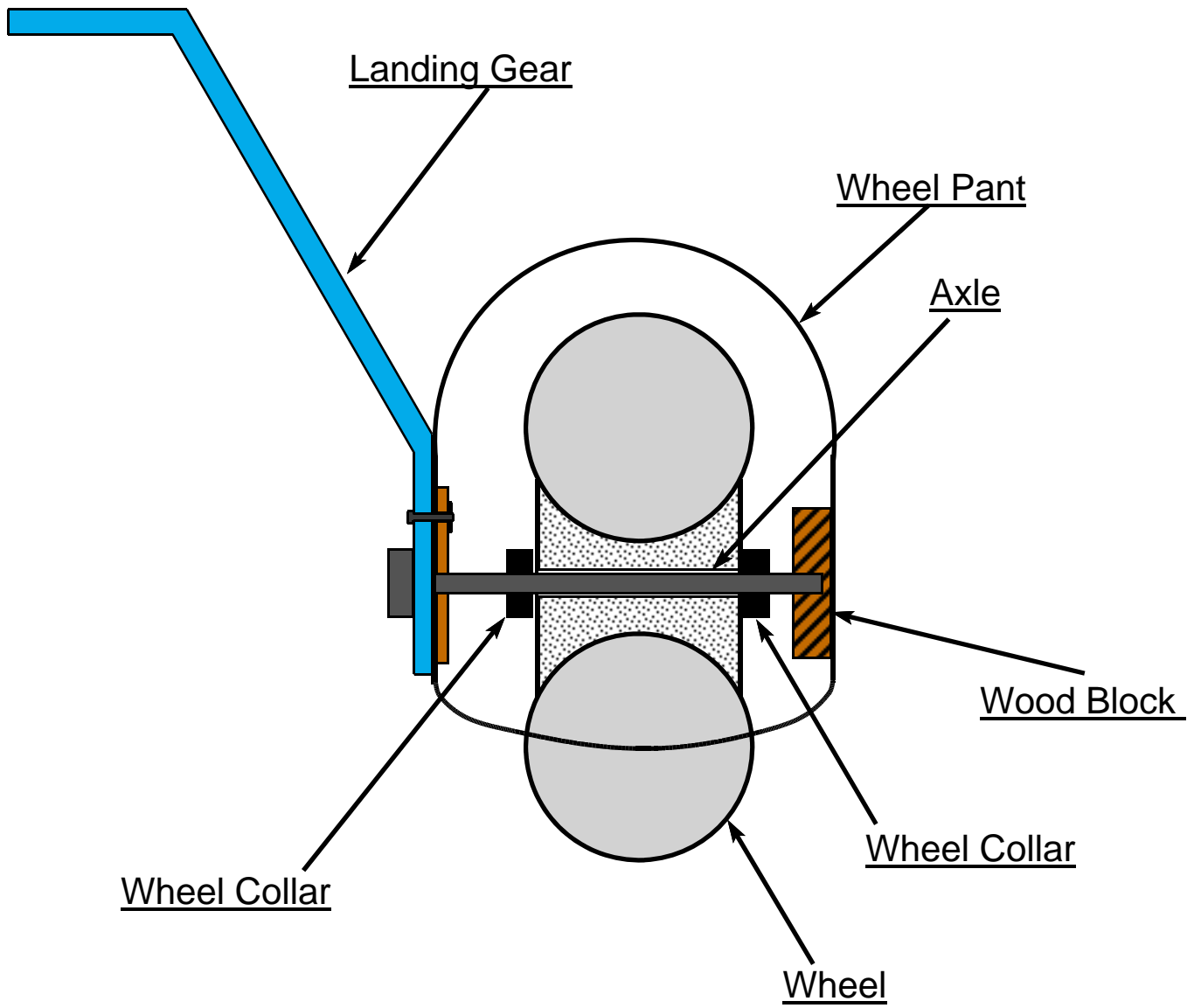

STEP 4: Re-install all components to complete assembly

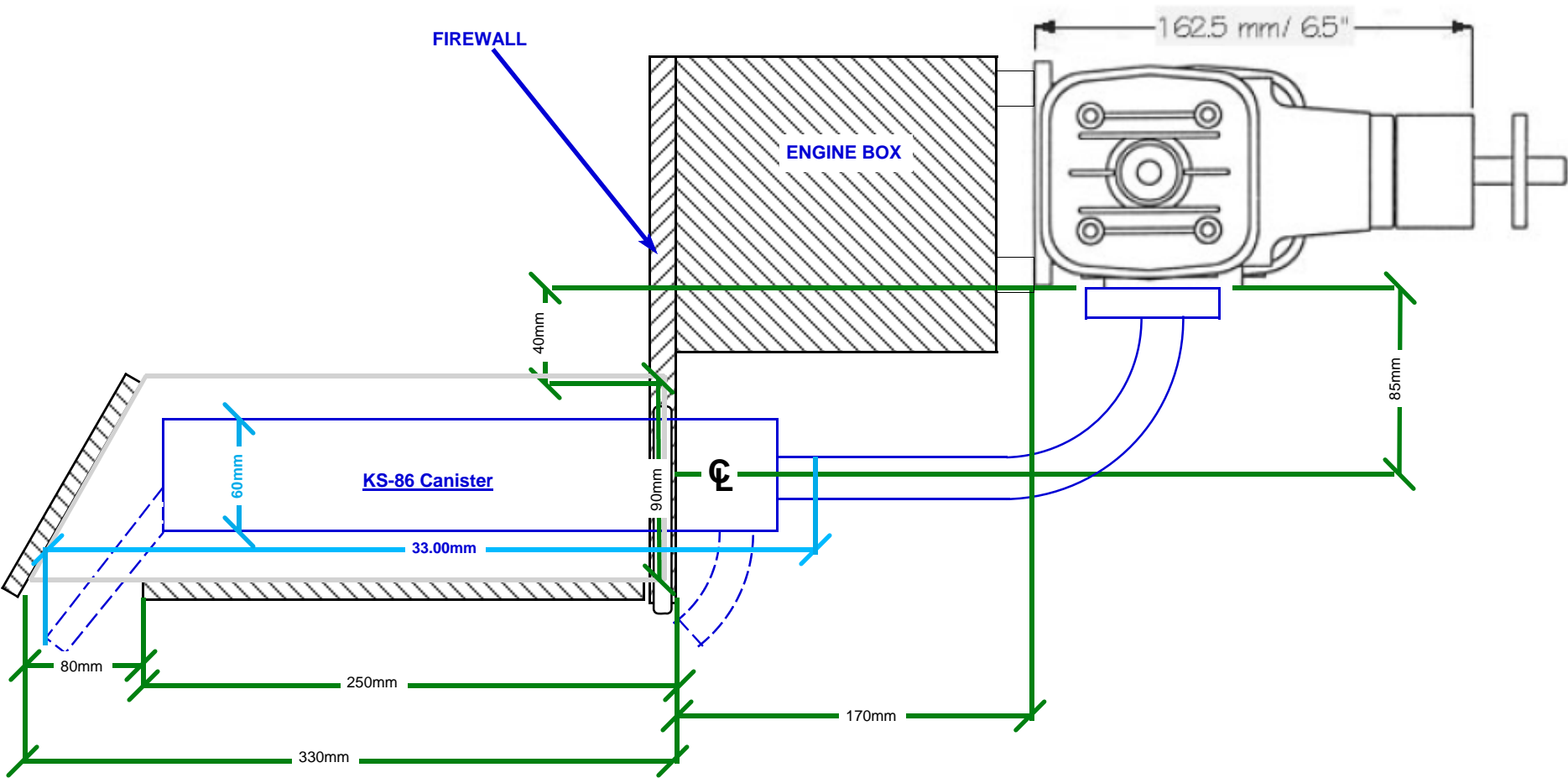

36% EDGE / DA-100 Canister Set Up